



## High Bay/Low Bay Passive Infrared Dual Relay Occupancy Sensor

Cat. No. OSFHD-\*AW (Alternating Relay Sensor)

Cat. No. OSFHD-\*TW (Dual Relay Sensor)

Cat. No. OSFOA-00W (Adapter, sold separately)

Cat. No. OSFLO-00W (Adapter, sold separately)

The product models with input voltage of 120 - 347VAC have a motor rating of ¼ HP at 120VAC.

Compatible with electronic and magnetic ballasts, electronic and magnetic low-voltage transformers

### Load Ratings:

800VA @ 120VAC, 50/60Hz, Ballast

1000VA @ 230VAC, 50/60Hz, Ballast

1200VA @ 277VAC, 50/60Hz, Ballast

1500VA @ 347VAC, 50/60Hz, Ballast

**NOTE:** No Low Voltage or 480VAC units available with OSFHD.

## INSTALLATION INSTRUCTIONS

PK-93961-10-00-2B

### LIMITED 5 YEAR WARRANTY AND EXCLUSIONS

Leviton warrants to the original consumer purchaser and not for the benefit of anyone else that this product at the time of its sale by Leviton is free of defects in materials and workmanship under normal and proper use for five years from the purchase date. Leviton's only obligation is to correct such defects by repair or replacement, at its option. **For details visit [www.leviton.com](http://www.leviton.com) or call 1-800-824-3005.** This warranty excludes and there is disclaimed liability for labor for removal of this product or reinstallation. This warranty is void if this product is installed improperly or in an improper environment, overloaded, misused, opened, abused, or altered in any manner, or is not used under normal operating conditions or not in accordance with any labels or instructions. **There are no other or implied warranties of any kind, including merchantability and fitness for a particular purpose,** but if any implied warranty is required by the applicable jurisdiction, the duration of any such implied warranty, including merchantability and fitness for a particular purpose, is limited to five years. **Leviton is not liable for incidental, indirect, special, or consequential damages, including without limitation, damage to, or loss of use of, any equipment, lost sales or profits or delay or failure to perform this warranty obligation.** The remedies provided herein are the exclusive remedies under this warranty, whether based on contract, tort or otherwise.

For Technical Assistance Call:  
1-800-824-3005 (U.S.A. Only)  
[www.leviton.com](http://www.leviton.com)

### FOR CANADA ONLY

For warranty information and/or product returns, residents of Canada should contact Leviton in writing at **Leviton Manufacturing of Canada Ltd to the attention of the Quality Assurance Department, 165 Hymus Blvd, Pointe-Claire (Quebec), Canada H9R 1E9** or by telephone at **1 800 405-5320.**

PK-93961-10-00-2B

## FEATURES

- Fixture or electrical box mounted Passive Infrared Occupancy Sensor
- Integrated Rotational Photocell
- Dual Relay
- Alternating Relay for increased lamp life
- Adjustable Time Delay
- Manual and Auto Calibration

- 360 degree lenses for field-of-view (included):
  - Blue Lens = 8-25ft mounting height
  - White Lens = 20-40ft mounting height
- H.I.S. (High Inrush Stability) Technology
  - Zero Crossing
  - Robust Mechanical Latching Relays

- Aisle coverage: add included aisle mask to either lens option.
- Non-Volatile Memory, device returns to its last state during power interruption
- LED indicator light blinks when sensor detects motion, visible from long distance
- False Detection Circuitry

- 21" pre-stripped color coded wire leads
- Optional peel and stick mask kit
- Offset Adapters (sold separately)

## DESCRIPTION

Leviton's High Bay Occupancy Sensors, Cat. No. OSFHD, are specifically designed for high mounted areas such as warehouses, manufacturing and other high ceiling applications. The OSFHD installs directly to an industrial luminaire or an electrical junction box. It is a self-contained sensor and relays that detects motion using the passive infrared (PIR) to sense sources (such as a person entering a room) within its field-of-view (monitored space) and automatically switches lights ON. The controlled lights will remain ON until no motion is detected and the scheduled time-delay has expired. The OSFHD is supplied with two interchangeable lens rings that allows the user to select between a 360 degree High Bay or Low Bay pattern and an aisle pattern with the included aisle mask.

Cat. No. OSFHD is UL/cUL listed and conforms to California Title 24 requirements. The Sensor's High Bay lens are designed for 20 ft. to 40 ft. mounting heights for a symmetrical pattern which will provide coverage of 50' to 60' diameter (**refer to Figure 4 and 5**). The Low Bay lens is designed for 8 ft. to 20 ft. mounting heights for a symmetrical pattern which will provide coverage of 30' to 50' diameter (**refer to Figure 6**). The Sensor is sensitive to the heat emitted by the human body. In order to initially trigger the Sensor, the source of heat must move from one zone of detection to another.

Note that occupancy sensors respond to rapid changes in temperature, so care should be taken not to mount the device near a climate control source (i.e. radiators, air exchanges, and air conditioners). Hot or cold drafts will look like body motion to the device and will trigger it if the unit is mounted too close.

**Mount the Occupancy Sensor 6 ft. from the heating or cooling ventilation source.**

## INSTALLATION INSTRUCTIONS

**WARNING:** CONTROLLING A LOAD IN EXCESS OF THE SPECIFIED RATINGS WILL DAMAGE THE UNIT AND POSE RISK OF FIRE, ELECTRIC SHOCK, PERSONAL INJURY OR DEATH. CHECK YOUR LOAD RATINGS TO DETERMINE THE UNIT'S SUITABILITY FOR YOUR APPLICATION.

**WARNING:** IF YOU ARE NOT SURE ABOUT ANY PART OF THESE INSTRUCTIONS, CONSULT AN ELECTRICIAN.

**WARNING:** TO BE INSTALLED AND/OR USED IN ACCORDANCE WITH ELECTRICAL CODES AND REGULATIONS.

### OTHER CAUTIONS AND NOTES:

1. **DISCONNECT POWER WHEN SERVICING LUMINAIRE OR CHANGING BULBS.**
2. USE THIS DEVICE WITH **COPPER OR COPPER CLAD WIRE ONLY.**
3. DO NOT ATTEMPT TO DISASSEMBLE OR REPAIR. CLEAN OUTER SURFACE WITH A DAMP CLOTH ONLY.

### TO INSTALL:

**NOTE:** The OSFHD is supplied with two lens trim rings. The 360 degree High Bay lens (white color trim ring) is installed at the factory with the Low Bay lens (blue color trim ring) in the carton. Choose the correct lens for your fixture height location and add the black aisle mask if desiring to block detection outside of the aisle. See below for changing lens trim ring. The OSFHD Sensor mounts in a 1/2" knock out hole on the end of a luminaire or an electrical box. The Sensor's field-of-view may be partially obstructed by the luminaire housing (**refer to Figure 1A**). At higher mounting heights, the outer beams are not used. As long as the bottom of the sensor is mounted within 1" from the bottom of the luminaire, the field-of-view will not be affected (**refer to Figure 1B**).

**ADAPTER NOTE:** For deep bodied luminaires or to clear other obstructions use Leviton's OSFOA-00W Adapter. The Adapter is designed to provide multiple mounting positions to accommodate different mounting heights for optimum sensor positioning. A keyed, threaded snap-in nipple that holds the Adapter in place while tightening the provided lock-nut. The OSFLO is a single height position adapter with a quick install snap in fitting without a lock nut.

### SENSOR INSTALLATION:

1. **WARNING:** TO AVOID FIRE, SHOCK, OR DEATH: **TURN OFF POWER** AT CIRCUIT BREAKER OR FUSE AND TEST THAT THE POWER IS OFF BEFORE WIRING.
  2. The sensor comes with two lens rings, a white one for 360 degree High Bay detection (installed at factory), and a blue one for Low Bay applications.
 

**NOTE:** Masking is provided to customize your detection area. Aisle mask can be inserted inside the lens and an optional peel and stick masking kit is included. This circular white adhesive label (with removable wedges) is applied to the OUTSIDE of the sensor lens. Use any number of wedges to alter field-of-view for your desired application.
  3. To change lens, turn trim ring so that the two indented dots line up and pull out by the finger tabs (**refer to Figure 7A**).
  4. Remove the lock-nut from the threaded nipple and insert the wires and the threaded nipple into a half inch hole of the luminaire body or the electrical box.
 

**NOTE:** Mounting nipple has a "snap" feature for quick installation into round or "double-D" holes, as well as a "keying" mechanism to prevent rotation after installation in "double-D" holes.
  5. Slide the lock-nut over the wires and thread clockwise on to the threaded nipple to secure the sensor firmly in place making sure the lens is orientated towards the area to be monitored (field-of-view) (**refer to Figure 3**).
  6. Connect wires per **Wiring Diagram** as follows: BLACK leads to LINE (Hot); RED/BLUE leads to LOAD; WHITE to Neutral. Twist strands of each lead tightly and, with circuit conductors, push firmly into the appropriate wire connector. Screw connector on clockwise making sure that no bare wire shows below the connector.
  7. Restore power at circuit breaker or fuse.
- NOTE:** Allow approximately 1 minute for charge-up. If the lights turn ON and the LED blinks when a hand is waved in front of the lens, then the Sensor was installed properly. If the operation is different, refer to the Troubleshooting Section.

The Sensor is factory preset to work without any adjustments. If you desire to change the factory settings, refer to the **SETTINGS** section.

All dual relay product models (OSFHD-ITW and OSFHD-CTW) shall have the following wire pigtails exiting from the enclosure (**refer to Table 5: OSFHD-IT and OSFHD-CT Wire Table**).

- The Red (Load 1) wire shall be labeled "Load 1" approximately 2" from the wire exit point from the housing nipple.
- The Blue (Load 2) wire shall be labeled "Load 2" approximately 2" from the wire exit point from the housing nipple.

All alternating relay product models (OSFHD-IAW and OSFHD-CAW) have Load 1 and Load 2 wire pigtails exiting from the enclosure (**refer to Table 6: OSFHD-IA and OSFHD-CA Wire Table**).

## SETTINGS AND CALIBRATION

**Time-Delay:** Settings should be determined during the installation period. This adjustment controls the amount of time the lights stay ON after the last detected motion. You may select settings varying from 30 seconds to 30 minutes for the primary relay, and 0 hours to infinity for the secondary relay. 0 hours on the secondary relay will result in both relays timing out simultaneously. The time delay on the secondary relay will not begin until the primary relay has timed out.

### Calibration:

1. Power up device (1 second PIR stabilization, 1 minute total charge time)
2. Decide on Manual or Auto configuration (Auto Recommended)
3. Manual Calibration:
  - Manual calibration should be done when ambient light is at user's desired brightness
  - Position photocell towards incoming light
  - Turn dial to SET/OFF for 5 seconds
  - LED blinks
  - Turn dial back to 100% setpoint, this determines DDL (Design Daylight Level)
  - LED blinks for 5 minutes
    - Verify DDL by turning dial above and below 100% to cycle the load
  - To Cancel Manual Calibration
    - Turn dial to SET/OFF for five seconds
    - Begin desired calibration process (Auto or Manual) over
4. Auto Calibration:
  - Turn dial to AUTO for 5 seconds
  - LED Blinks
  - Initiates 24 hour calibration sequence
  - After 24 hours the DDL is set
  - Cancel Auto Calibration
    - Move dial to % then back to AUTO
    - Begin desired calibration process (Auto or Manual) over
5. Disable Photocell
  - To disable photocell complete turn dial to SET/OFF

### Adjusting the Setpoint (DDL):

1. If lights turn OFF to soon:
  - A: Rotate photocell to remove direct light
  - B: Raise Setpoint above 100% a small amount (repeat as needed)
2. If lights stay ON longer than needed:
  - A: Rotate photocell toward more reflective incoming light
  - B: Lower Setpoint below 100% a small amount (repeat as needed)

**NOTE:** There is approximately five minute delay to turn the loads off, and approximately one minute delay to turn loads on with Daylighting feature.

FACTORY SETTINGS	
Configuration	Value
Load/Timer 1	30 seconds
Load/Timer 2	0 Hours
PIR Sensitivity	75% of Maximum
Photocell Set Point	Off
Installed Lens	Grey, High Bay
Lens Position	Zero rotation position, Lens tabs aligned with side 90° markings.

### Alternating Relay Sensor

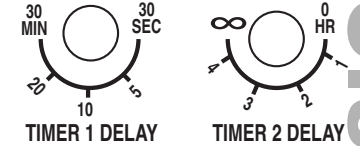

### Dual Relay Sensor

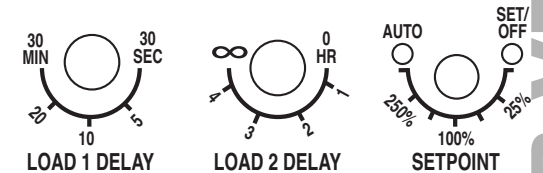

Table 5  
OSFHD-IT and OSFHD-CT Wire Table

Color	Description
Black	Line
Red	Load 1
Blue	Load 2
White	Neutral

Table 6  
OSFHD-IA and OSFHD-CA Wire Table

Color	Description
Black	Line
Red	Load 1
Blue	Load 2
White	Neutral

WEB VERSION

## OPERATION

### Operational:

#### 1. Dual Relay Application:

- A stepped implementation provides both reduced lighting and energy savings when occupancy is not detected.
- For dual relay product models the load connected to the primary time delay control shall always be turned OFF when the primary time delay expires.
- For dual relay product models the load connected to the secondary time delay control shall always be turned OFF when the secondary time delay expires.

#### 2. Alternating Relay Application:

- Alternating the external load assignment to the primary time delay control distributes the time a specific load is in the ON state, resulting in extended lamp life.
- For alternating relay product models the external load assignment to the primary and secondary time delay controls shall alternate after primary time delay expires and occupancy is detected.
- For alternating relay product models the external load assignment to the primary and secondary time delay controls shall alternate after both timers expire and occupancy is detected.

#### 3. Timer Delay Application:

- The primary time delay shall start counting (or restart) from time zero whenever the sensor detects movement.
- For single load product models the sensor shall change state to unoccupied when the primary time delay expires.
- The secondary time delay shall start counting from zero when the primary time delay expires.
- If the secondary time delay control is set to Infinity the sensor shall always remain in the occupied state.
- For dual load product models the secondary time delay shall be disabled and primary time delay restarted whenever the sensor detects movement.

### Photocell and Daylighting Operations:

Daylighting is used for additional energy savings. For all models, load one is affected by the photocell. The photocell holds the lights off when sufficient ambient light is available. Typical light level is measured in foot candles or lux, and average office rooms are designed to 50-60 foot candles/500-600 lux. The design daylight level when set per calibration section will be the setpoint and engage the light hold-off feature of daylight harvesting.

- Rotating the photocell on these devices can create a closed loop system (most common), an open loop system or some of each.
- When the photocell is pointed up, it is typically pointed at a skylight. It will only detect daylight. There will be little or no contribution from the fixtures. The graph in **Figure 2A** tracks the value of a linear photocell throughout a day. It is assumed that it is a cloudless day so the increase and decrease of the daylight is relatively linear. The far left of the graph starts out at night and shows a very low level reading. At dawn, the level begins to increase. At some point, based on the setting of the trigger point, the lights will be turned off since there is enough contribution from the daylight. The photocell reading will begin to decrease around noon until the level matches the trigger point, then lights will be turned back on.
- When there is little or no light contribution from the fixtures, the system is relatively simple and stable. In order to keep the lights from needlessly cycling on and off, the off trigger point is usually set at a higher light level than the on trigger point. In addition, there is usually a delay time that must be met which requires the light level to be above or below the trigger point for a period of time before a light change occurs. For example, there may be a 5% hysteresis gap between the off and on trigger points along with a 5 minute delay time to turn off the load and 1 minute time delay to turn on the load.
- When the sensor is pointed down, it will typically detect light contributions from both the fixtures it controls and the ambient light from outside sources. This establishes a closed looped system. Switching loads off in a closed loop system rather than dimming can cause complications if not programmed properly. The graph in **Figure 2B** tracks the value of a linear photocell throughout a day. It is assumed that it is a cloudless day and that the desired light level is the same level without external light influence and only by the fixtures. At the far left, the lights are on because the area is occupied and since it is still night, there is no contribution from daylighting. As dawn arrives, the photocell level begins to increase as the daylight increases. In order to keep the light level from dropping below the trigger point, and in this case below the desired light level in the area, the trigger point is set to 2.5 times the level read with only the fixtures. That way, the light is still adequate to hold the lights off. This is shown in the graph at the point where the level suddenly drops. The photocell level then continues to increase until around noon. As the daylight decreases, the area light eventually drops to near the desired light level. Before reaching this point the lights are turned back on indicated by the sudden increase in the photocell level.

## TROUBLESHOOTING

- **Lights will not turn ON**
  - **Circuit breaker or fuse is OFF:** Turn the breaker ON. Ensure the lights being controlled are in working order (i.e., working bulbs, ballasts, etc.)
  - **Sensor is wired incorrectly or may be defective:** Confirm that the sensor's wiring is done correctly and inspect visually for problems.
  - **Lens is dirty or obstructed:** Inspect the lens visually and clean if necessary, or remove the obstruction.
- **Lights will not turn OFF**
  - **Sensor is wired incorrectly or may be defective:** Confirm that the sensor's wiring is done correctly and inspect visually for problems.
  - **Sensor may be mounted too closely to an air conditioning or heating vent:** Move the sensor or close the vent.
  - **The line voltage has dropped:** Perform the necessary tests to ensure the line voltage has not dropped beneath 100V.
- **Lights turn OFF and ON too quickly**
  - **Sensor may be mounted too closely to an air conditioning or heating vent:** Move the sensor to another location or close the vent.
  - **Time delay set improperly:** Adjust the TIME DELAY.
- **Load cycling ON and OFF intermittently**
  - **Verify photocell daylight operation is set to the desired mode (manual or auto)**
  - **Adjust rotational photocell to prevent intermittent load cycling (ON/OFF)**
  - **If problem persists, adjust setpoint dial (increase value) to prevent load cycling**

## CERTIFICATIONS

- **Line Voltage Units**
  - All 120-347VAC Models meet all requirements and pass certification testing per UL 916 and CSA 22.2 No. 205 M1983.

Figure 1A

### INCORRECT

Sensor mounted too high  
Outer beams are obstructed  
Field-of-view is limited

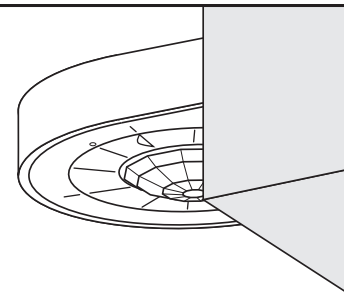

Figure 1B

### CORRECT

Sensor mounted within 1" of bottom  
No obstruction  
Optimum field-of-view

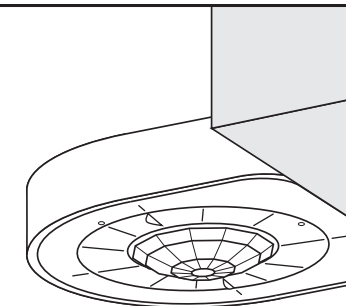

Figure 2A

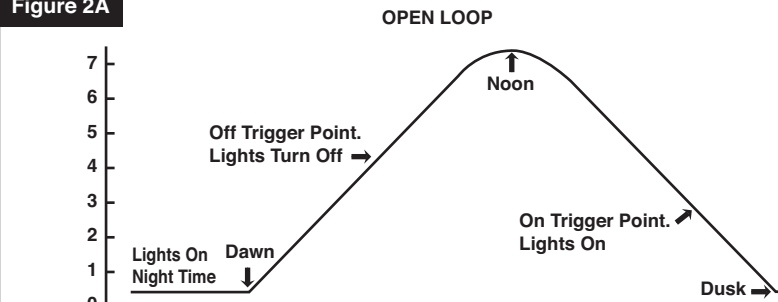

Figure 2B

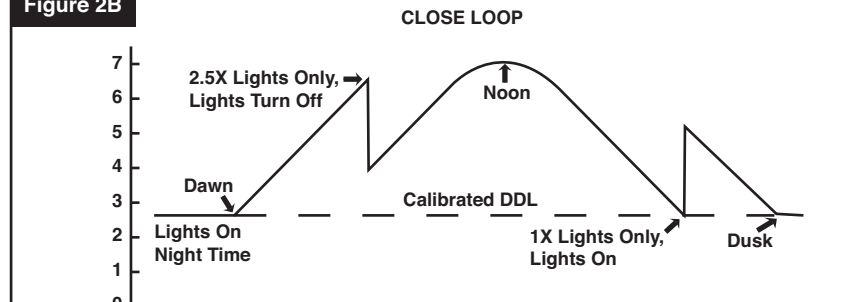

Figure 3

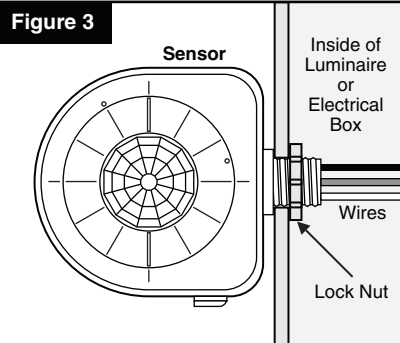

Figure 4

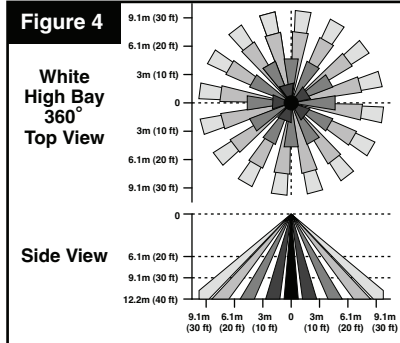

Figure 5

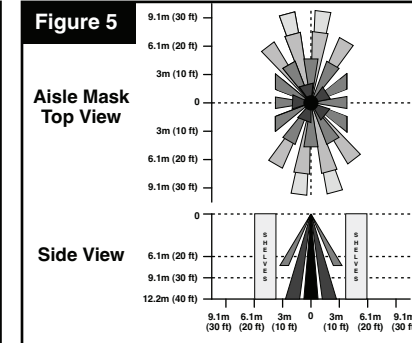

Figure 6

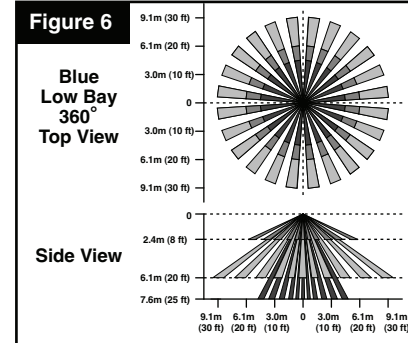

Figure 7A

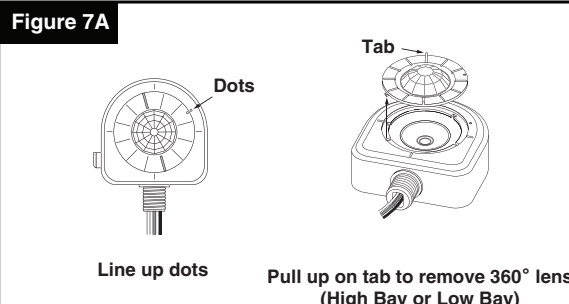
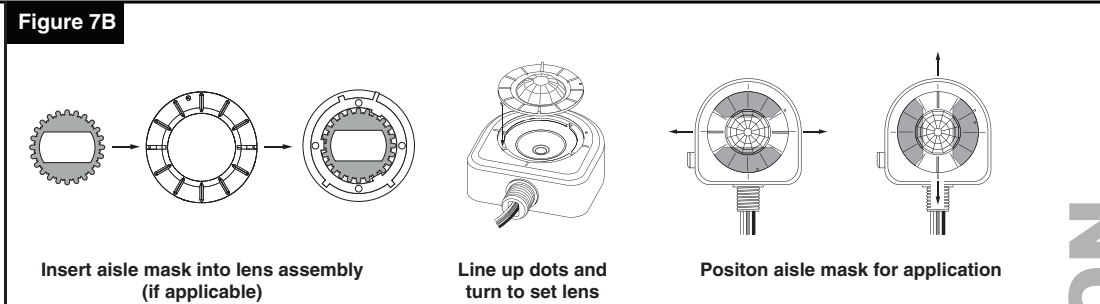

Figure 7B



Alternating & Dual Relay Wiring Diagram

