

## DuraPort® Industrial Outlet Kit

### APPLICATION

DuraPort industrial products provide IP67-class protection to safeguard your connectivity from humidity/moisture, corrosive materials, temperature extremes, and other conditions often found in the industrial environment.



### SPECIFICATION

Single-gang and dual-gang industrial outlet kits shall fit standard NEMA boxes. The single-gang outlet kit shall provide 1 or 2 ports and an equivalent amount of connector housings and dust caps assembled. The dual-gang outlet kit shall provide 2 or 4 ports and an equivalent amount of connector housings and connector caps assembled. Connector housing shall accept all standard Leviton QuickPort® modules. Connectors and related components shall be IP67 rated. Wallplate shall be constructed of stainless steel, with an integral over-molded gasket. Connector housing shall be made of PBT, be cULus listed, and compliant with ANSI/TIA-1005.

### COUNTRY OF ORIGIN

USA

### WARRANTY INFORMATION

For a copy of Leviton product warranties, visit [www.leviton.com/warranty](http://www.leviton.com/warranty).

### FEATURES

- IP67-rated environmental sealing (dust/water protection)
- Industrial Outlet Kit includes pre-assembled stainless-steel wallplate, and equivalent number of connector caps and housings for quick and easy ordering
- Over-molded wallplate gasket ensures watertight fit
- Wallplate mounting holes have embedded sealing feature which provides the dual benefit of sealing, and helping to ensure proper orientation during installation of wallplate
- Available in single-gang configurations of 1 or 2 ports and dual-gang configurations of 2 or 4 ports
- Twist-lock design for faster installation and changes
- Encapsulated RJ-45 design protects integral components
- Patented design

### DESIGN CONSIDERATIONS

- Uses standard Leviton QuickPort opening to easily replace, or upgrade performance without replacing entire outlet
- Compatible with standard NEMA boxes
- DuraPort Industrial Patch Cords, and QuickPort connectors sold separately

### STANDARDS COMPLIANCE

cULus Listed; complies with ANSI/TIA-1005 and ANSI/TIA-568. cULus Listed (UL 1863, CAN/CSA-C22.2 No. 182.4-1990).

### PHYSICAL SPECIFICATIONS

<b>Ingress Protection:</b>	IP67 (dust/water)
<b>Temperature:</b>	-40°C to 65°C (-40°F to 149°F)
<b>Vibration:</b>	
Frequency Range	10-500Hz
Acceleration	5g (operational)
<b>Mating Cycles:</b>	750 minimum
<b>Materials:</b>	
Connector Housing	Polybutylene terephthalate (PBT)
Wallplate Type	302 Stainless Steel
Mounting Screws	Type 18-8 Stainless Steel
Wallplate Gasket	Thermoplastic Elastomer

#### Leviton Network Solutions

2222 - 222nd St. SE  
Bothell, WA 98021-4416

tel 1-800-824-3005  
tel +1-425-486-2222  
appeng@leviton.com  
[www.leviton.com](http://www.leviton.com)

#### Asia / Pacific

T +1.631.812.6228  
E infoasean@leviton.com

#### Europe

T +44.0.1592.772124  
E customerserviceeu@leviton.com

#### Canada

T +1.514.954.1840  
E pcservice@leviton.com

#### Mexico

T +52.55.5082.1040  
E lsamarketing@leviton.com

#### Caribbean

T +1.954.593.1896  
E infocaribbean@leviton.com

#### Middle East & Africa

T +971.4.247.9800  
E lmeinfo@leviton.com

#### China

T +852.2774.9876  
E infochina@leviton.com

#### South Korea

T +82.2.3273.9963  
E infokorea@leviton.com

#### Colombia

T +57.1.743.6045  
E infocolombia@leviton.com

**ELECTRONIC FILES**

For CAD files, typical specs, or technical drawings (.DXF, .DWG), visit [www.leviton.com](http://www.leviton.com).

**The DuraPort® System**

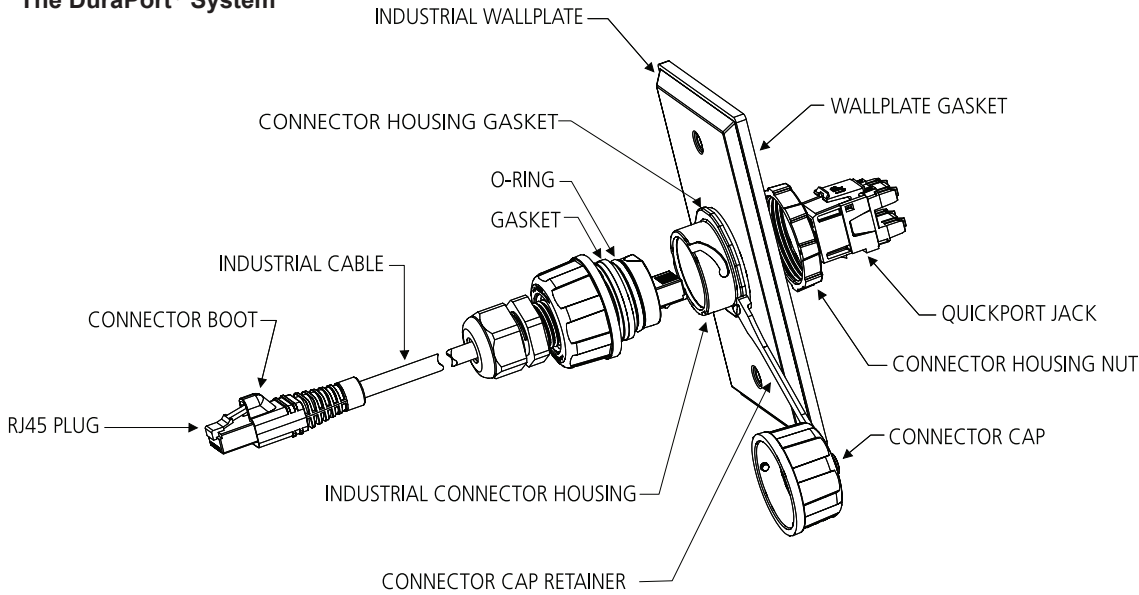

**D670K-xSx**

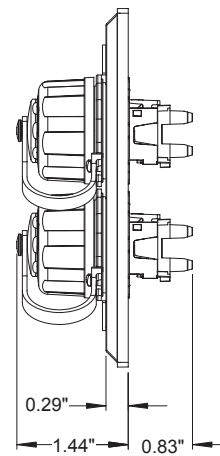
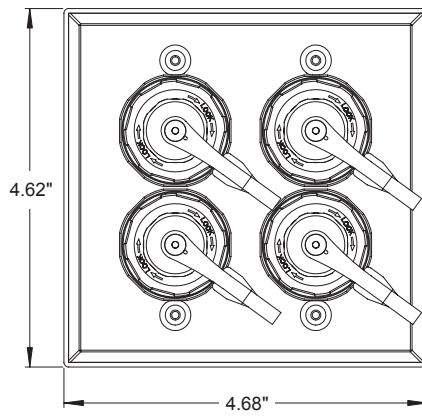
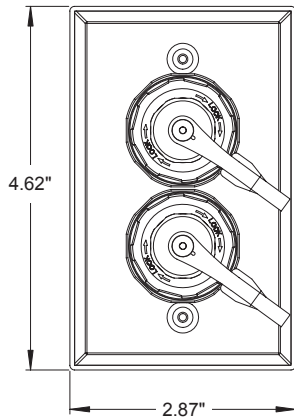

**DURAPORT INDUSTRIAL OUTLET KIT**

Description	Part No.
DuraPort Industrial Outlet Kit, Single-Gang, 1 port	D670K-1S1
DuraPort Industrial Outlet Kit, Single-Gang, 2 ports	D670K-1S2
DuraPort Industrial Outlet Kit, Dual-Gang, 2 ports	D670K-2S2
DuraPort Industrial Outlet Kit, Dual-Gang, 4 ports	D670K-2S4

**Leviton Network Solutions**

2222 - 222nd St. SE  
Bothell, WA 98021-4416

tel 1-800-824-3005  
tel +1-425-486-2222  
appeng@leviton.com  
[www.leviton.com](http://www.leviton.com)

**Asia / Pacific**  
T +1.631.812.6228  
E infoasean@leviton.com

**Europe**  
T +44.0.1592.772124  
E customerserviceeu@leviton.com

**Canada**  
T +1.514.954.1840  
E pcservice@leviton.com

**Mexico**  
T +52.55.5082.1040  
E lsamarketing@leviton.com

**Caribbean**  
T +1.954.593.1896  
E infocaribbean@leviton.com

**Middle East & Africa**  
T +971.4.247.9800  
E lmeinfo@leviton.com

**China**  
T +852.2774.9876  
E infochina@leviton.com

**South Korea**  
T +82.2.3273.9963  
E infokorea@leviton.com

**Colombia**  
T +57.1.743.6045  
E infocolombia@leviton.com