

# D4200 A/V Interface

+9-24Vdc, 50mA @ 12V, 25mA @ 24V



DI-000-D42AV-00B AR2691

### WARNINGS AND CAUTIONS:

- **TO AVOID FIRE, SHOCK OR DEATH: TURN OFF POWER AT MAIN CIRCUIT BREAKER OR FUSE AND TEST THAT THE POWER IS OFF BEFORE WIRING, SERVICING THE DIMMER OR CHANGING BULBS!**
- **DO NOT CONNECT LINE VOLTAGE WIRES TO LOW VOLTAGE TERMINALS.**
- TO BE INSTALLED AND/OR USED IN ACCORDANCE WITH ELECTRICAL CODES AND REGULATIONS.
- IF YOU ARE NOT SURE ABOUT ANY PART OF THESE INSTRUCTIONS, CONSULT AN ELECTRICIAN.
- FOR INDOOR USE ONLY.
- FOR THE BEST LAMP LIFE, LAMP MANUFACTURERS RECOMMEND THEIR FLUORESCENT LAMPS SHOULD BE OPERATED AT FULL BRIGHTNESS FOR A MINIMUM OF 100 HOURS BEFORE DIMMING IS PERMITTED. FOR BEST RESULTS, LAMP BRANDS AND TYPES SHOULD NOT BE INTERMIXED ON A CIRCUIT.

### INTRODUCTION:

For best results using the Dimensions 4200 Architectural Lighting Controller, Follow these recommendations:

1. Plan the system before beginning the installation
2. Terminate the wiring
3. Test the wiring
4. Connect dimmer cabinets
5. Power up the Stations
6. Program each Station
  - Assign unique network ID numbers to stations.
  - Connect one master station, and then one remote control station at a time.
  - Verify that the first D4200 can properly control the dimmers assigned to it.
  - Check the proper operation of each station as it is installed when multiple stations are involved.
7. Install all Stations

**NOTE:** If the lighting control fails or becomes sporadic, first check the wiring or network ID.

### TERMINATING THE WIRING:

#### Luma-Net® III

Control Stations can be located up to 2000 ft. from the dimming cabinet. Luma-Net® is wired Daisy Chained, station to station. For applications where runs become too long contact Technical Support at 1-800-959-6004. The cable should not pass near any source of electrical noise such as fluorescent circuits or motor wiring. Avoid close proximity to any AC wiring. All control/power wiring must be in conduit.

#### Luma-Net® Wire Recommendations

1. Use RS485 compatible cable for communications. It is recommended that a cable with 2 Twisted Pair, 24 AWG (min.), stranded conductors be used. The spare pair is for future uses.
2. Capacitance of wire shall be 15pF/ft. or less.
3. Normal Impedance of wire shall be between 100-120 ohms.
4. A second pair of stranded wire is required for the power.
5. Drain/Shields to be tied together, insulated and grounded at one point only.

**We strongly recommend the use of either Belden 9829, Belden 9729 or Belden 1502R/1502P for the Luma-Net® wire runs.**

Figure 1 - Typical Daisy Chain wiring scenario

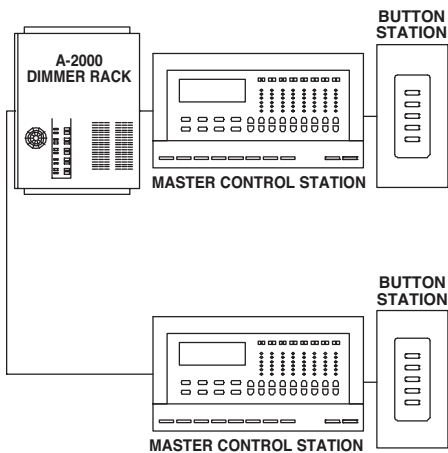

Figure 2 - Dis-allowed star topology (DO NOT USE)

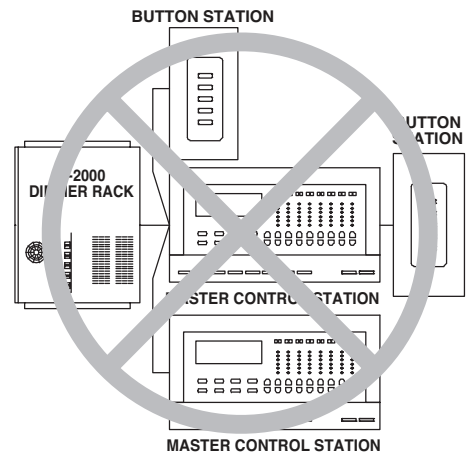
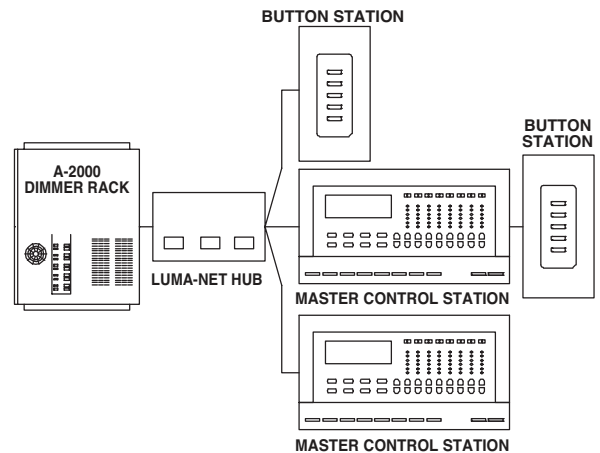

Figure 3 - Allowed star topology (with Luma-Net Hub only)



If a remote DC power supply is used and you have multiple Luma-Net® runs, all DC common wires must be joined at the power supply.

At the last control station or dimmer cabinet on both ends of run, a small jumper wire must be run from the terminal labeled "Rem-" to the terminal marked "Term" on that last station. This jumper wire properly terminates the digital communications lines at both ends of the line.

### Wire the Phoenix Connector

1. Connect leads per wiring diagram (see Luma-Net® Wire Connections).
2. Twist strands of each lead tightly (making sure that there are no stray strands) and push firmly into appropriate plug connector location.
3. Tighten the screws on the plug connector-making sure that no bare conductor is showing.
4. Tie the Drain/Shield wires together and insulate using a small piece of heat shrink tubing.
5. Install termination jumpers as required. Remember a termination jumper is required at the two ends of the Luma-Net® run.

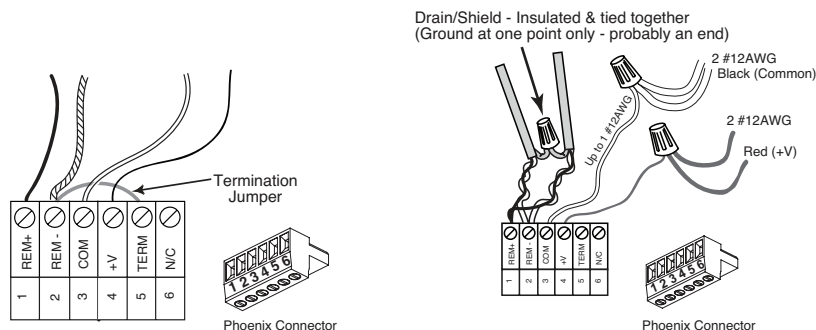

Luma-Net® Termination Jumper Locations

Luma-Net® Wire Connections

## TESTING THE WIRING:

To assure problem-free start-up, it is important to check the system wiring, prior to hooking up any control stations, for proper connections, shorts and opens.

The following procedure is recommended:

**Step 1:** Test the following wire pairs for shorts at each station location, using an ohmmeter or other continuity tester.

- 1-2 Open
- 2-3 Open
- 3-4 Open

**Step 2:** Repair any short circuits before continuing.

**Step 3:** Install wire jumpers to the Phoenix Connector (not supplied) on either end of the cable run between pins 3-4.

**Step 4:** Retest each of the following wire pairs at each connector:

- 1-2 Open
- 2-3 Open
- 3-4 Short

**Step 5:** Make any necessary repairs and remove wire jumpers before continuing.

## STATION ADDRESSING:

Address the A/V interface between 1 and 127. If a station address is set to Zero it will not participate on the network.

The switch is set to the binary representation of the ID number. The binary 1's column is left-most (lever labeled "1").

The switch levers are numbered 1-8, these represent the following:

Lever=Value

1=1      2=2

3=4      4=8

5=16     6=32

7=64     8=Selects code V1.x (ON) or V2.x (OFF)

Add the value of each lever in the "ON" position to determine the ID number (decimal form).

**For example:**

To set the address to 39, the following switches need to be in the "ON" position: 1, 2,3,6 = 1+2+4+32=39

## INSTALLATION:

Securely mount the entry station using the screws provided.

If you are using a screwless snap on plate, remove the center tabs of the strap as shown in the figure.

## PROGRAMMING / OPERATION:

The D42AV responds to ASCII control commands which can be issues through a common RS-232 terminal connection.

For connecting to the A/V interface, use the following parameters

- Baud Rate (BPS): 9600
- Data Bits: 8
- Stop Bits: 1
- Parity: None
- Flow Control: None
- For testing purposes, a terminal program like Hyper Terminal, Terra Term, or other serial terminal communication program can be used.

## ASCII Commands

You can initiate the following commands (leading zeros are not required):

**Note:** Legacy command required for use when interfacing with older D4200 network control stations or when needing to recall MAX/OFF commands. Newer versions D4200 support both D4200 and D8000 button press commands. D8000 button press commands can be used with D4200, D8000, and the Combine Closures (KCLCM) interface.

### D4200 Preset/Scene button

Pxx@yyy = send D4200 scene button.

Pscene@netid      e.g. P18@53

xx = 1 to 2 digit scene number 1-16, 17=Max, 18=Off.

### D8000 button press

K\_xx@\_yyy = send D8000 button press.

K = button@netid

xx = 2 digit switch number 01-15

e.g. K9@101

### Dimmer @ Level

Ddddd@lll = send dimmer level.

Ddimmer@level      e.g. D81@128

dddd = dimmer number, 1-2048.

lll = 3 digit level number, 0-255.

### Set Dimmer Fade rate

Fxxx = set fade rate for 'D'.

Ffaderate      e.g. F5

xxx = fade rate, 0-60seconds, above 60 is minutes.

0 - 59 = seconds

60 - 239 = 1 to 180 minutes

253 = Photocell Capture or record (a-2000)

254 = Photocell On (a-2000)

255 = Stop fading now or Stop Fade

Follow the simple formula of: Total minutes + 59 = entry

Example: For 65 minutes enter 124 (65+59 = 124)

### Dimmer to Max

Rxxxx = send raise dimmer 1-2048 to Max.      e.g. R22

### Dimmer to Off

Lxxxx = send lower dimmer 1-2048 to Off.      e.g. L22

### Dimmer Stop

Sxxxx = send stop to dimmer 1-2048.      e.g. S22

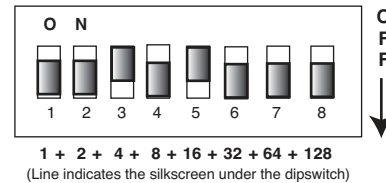

Net ID

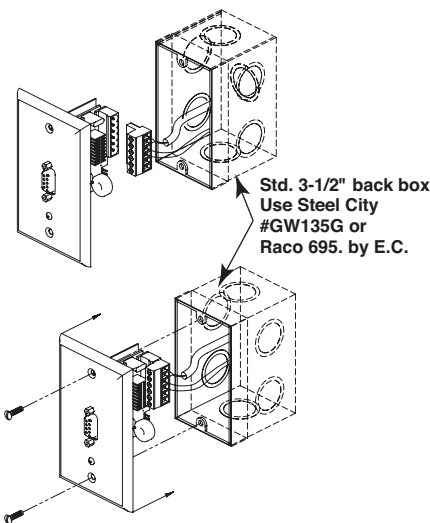

### Dimmer Read back

Vxxxx = send read back request to dimmer 1-2048. V22 Returns 3 digit raw value, or 'NA' (Dimmer number not applicable).

The A/V Interface also has some tools for debugging automation sequences.

They are:

M\_aa@\_lll = set options.

Maddress@level      (e.g. M1@1)

aa = 2 digit address, 1 or 2.

lll = 3 digit level number, 0-255.

if aa = 01, then:

100 adds debug parsing echoing. (e.g. M1@100)

101 adds above and parsing quotes around parameters. (e.g. M1@101)

102 adds above and display of parsed numbers. (e.g. M01@102)

if aa = 02, then:

1 adds user prompt. (e.g. M2@1)

2 adds user prompt and error messages. (e.g. M2@2)

B = Display Software Build Number.

Z = Toggle Debug Network Mode Status Output.

**NOTE:** You must press the Return/Enter key to execute the desired command.

## Limited Warranty

LEVITON LIGHTING AND ENERGY SOLUTIONS A DIVISION of Leviton Manufacturing Co Inc. warrants its Dimmer Systems and Controls to be free of material and workmanship defects for a period of two years after system acceptance or 26 months after shipment, whichever comes first. This Warranty is limited to repair or replacement of defective equipment returned Freight Pre-Paid to Leviton Lighting Control Division at 20497 SW Teton Ave., Tualatin, Oregon 97062, USA. User shall call 1-800-959-6004 and request a return authorization number to mark on the outside of the returning carton, to assure that the returned material will be properly received at Leviton. All equipment shipped back to Leviton must be carefully and properly packed to avoid shipping damage. Replacements or repaired equipment will be returned to sender freight prepaid, F.O.B. factory. Leviton is not responsible for removing or replacing equipment on the job site, and will not honor charges for such work. Leviton will not be responsible for any loss of use time or subsequent damages should any of the equipment fail during the warranty period, but agrees only to repair or replace defective equipment returned to its plant in Tualatin, Oregon. This Warranty is void on any product that has been improperly installed, overloaded, short circuited, abused, or altered in any manner. Neither the seller nor Leviton shall be liable for any injury, loss or damage, direct or consequential arising out of the use of or inability to use the equipment. This Warranty does not cover lamps, ballasts, and other equipment which is supplied or warranted directly to the user by its manufacturer. Leviton makes no warranty as to the Fitness for Purpose or other implied Warranties.