

Intellect™ Power Control Module
Cat. No. ZL027

PK-A3249-10-00-2B

WARNINGS

- **TO AVOID FIRE, SHOCK, OR DEATH; TURN OFF POWER AT CIRCUIT BREAKER OR FUSE AND TEST THAT POWER IS OFF BEFORE WIRING, SERVICING, OR REMOVING FIXTURE OR CHANGING LAMPS!**
- **RISK OF ELECTRIC SHOCK** - More than one disconnect switch may be required to de-energize the equipment before servicing. Disconnect both normal and emergency sources within this unit before servicing any equipment connected to this unit.
- "EMERGENCY CIRCUITS" enclosed label should be placed in a location visible after installation so as to be readily identifiable as a component of the emergency system.

CAUTIONS

- Maximum distance between Sensor Head and Power Control Module is 10 feet (3m).
- Use only Intellect™ cable for connection between Sensor Head and Power Control Module. Alternate lengths are available should the one provided be too short or long.
- Power Control Module is intended to be installed by the fixture manufacturer, but in some cases may be installed in the field. When field installed the PCM must be installed into an approved electrical enclosure.
- Please refer to the fixture documentation for replacement information.
- Power Control Module & Emergency Sense must be installed inside the same enclosure. Sensor head may be external to the enclosure.
- Install and/or use in accordance with electrical codes and regulations.

CAUTIONS

- If you are not sure about any part of these instructions, consult an electrician.
- To avoid electrical overload, total connected fixture load shall not exceed output rating.
- Use for indoor applications only.
- Use this device with solid **copper or copper clad wire only**.
NOTE: Suitable for use in environmental air spaces (plenums) when installed in an approved electrical enclosure in accordance with Section 300.22(C) of the National Electrical Code, and Sections 2-128, 12-010(3) and 12-100 of the Canadian Electrical Code Part 1, CSA C22.1.

IMPORTANT SAFEGUARDS

When using electrical equipment, basic safety precautions should always be followed including the following:

- Read and follow all safety instructions
- Save these instructions
- Do not use outdoors.
- Do not mount near gas or electric heaters.
- Equipment should be mounted in locations and at heights where it will not be subjected to tampering by unauthorized personnel.
- The use of accessory equipment not recommended by the manufacturer may cause an unsafe condition.
- Do not use this equipment for other than its intended use.

INSTALLATION INSTRUCTIONS

ENGLISH

DESCRIPTION

This Intellect™ Power Control Module is designed to be used within an Intellect™ system and, in concert with Intellect™ Sensor Heads and Intellect™ enabled Room Controllers. There are several basic system components:

- **Room Controllers:** These are used to coordinate and control multiple Lumina RF fixtures and sensors within a room, specifically those with Intellect™ enabled technology. It manages all energy management functionality both as required by code and as desired by the user.
- **Sensor Heads:** Detects occupancy, light level, and wirelessly communicates to Room Controllers & other fixtures to coordinate activities within a room providing energy management and architectural controls functionality. Connects via the Intellect™ cable to load controls.
- **Power Control Modules:** Controls On/Off/Dimming state of load and provides metrology data to system and end user via the app.

All aspects of the system can be configured to meet the specific needs of the end-user and their application. An initial configuration can be created without any special tools using only the room controller and installed devices within the room. System refinements can be made using the Leviton Intellect™ app from your smartphone or other Bluetooth enabled Android or iOS device.

NORMAL (NON-EMERGENCY) WIRING

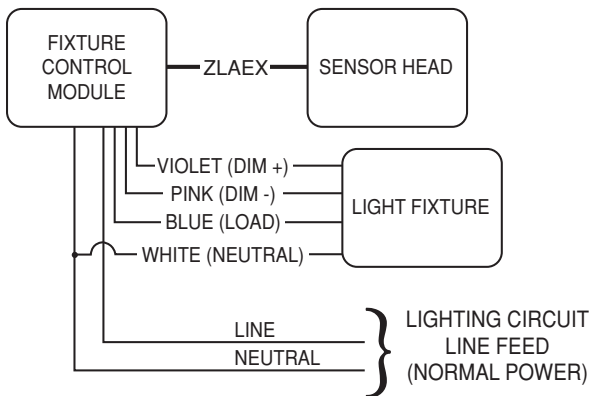

SPECIFICATIONS	
Part Number	ZL027-DLE
Input Rating*	120-277VAC, 50/60Hz Standby Power: <0.5W Max Input Power: 200mA
Switched Relay Load Ratings (120-277VAC)	2.5A Tungsten 2.5A Electronic Ballast, LED 2.5A Standard Ballast 2.5A Magnetic/Electronic Transformer
Sensor Control	6V, Class 2, Isolated Circuit
0-10V Dimming Control	0-10+VDC, 10mA sinking, wired as Class 1
Metrology	KWH (3%), KW, Power Factor, Voltage, Current, KVAR, KVARH
Mounting	Inside fixture using #6 3/16 sheet metal screw, or #6 machined screw with nut
Operational Temperature	Ambient Temperature Range: 32° to 131° F (0°-55°C) Critical Temperature (Tc) Inside Fixture: 85°C 0 to 90% Humidity non condensing
Certifications	FCC Part 15, Class A
IP Rating	Sensor = IP20 Power Pack = IP40 Emergency Sense Pack = IP40 Entry = IP30
Energy Code Compliance	Title 24 ASHRAE 90.1 IECC Advanced Lighting Controls DLC

* Input voltage tolerance 10%, Frequency tolerance 5%.

NOTE: Depending on date of manufacture, the pink 0-10V connector may be gray

INSTALLATION

1. **WARNING: TO AVOID FIRE, SHOCK, OR DEATH; TURN OFF POWER AT CIRCUIT BREAKER OR FUSE AND TEST THAT POWER IS OFF BEFORE WIRING!**
2. Mount the Power Control Module to the inside fixture using the #6-3/16 sheet metal screw, or #6 machined screw with nut.
3. Connect input power, load, and 0-10V control lines as appropriate per your application by following instructions below.
 - **Use 18-gauge Solid Core wire for ALL CLASS 1 WIRING**
 - Remove 1/4" (7 mm) of insulation from each circuit conductor
 - Make sure ends of conductor are straight
 - Push conductor firmly into appropriate wire connector
4. Connect the Power Control Module to a Sensor Head using a Leviton Intellect™ sensor head cable, part number ZLAEX. Ensure the cable is firmly seated into connection both in the Sensor Head and the Power Control Module.
5. If installing with Emergency Sense Module (ZL027-0ES), connect the Emergency Sense Module to the Power Control Module using the cable included with the ZL027-0ES. Connect the Emergency Sense Module to Normal Power
6. Restore power at circuit breaker or fuse. **INSTALLATION IS COMPLETE.**

WIRE DESIGNATIONS

Control Power In (120-277VAC)	Black
Control Neutral	White
Load (Load OUT)	Blue
0-10VDC Control	Violet
0-10VDC Common	Pink

OPERATION

- When power is applied, and the Sensor Head is connected, the system will operate in the out-of-box state where daylighting is active to an automatically calibrated target, and light turns ON upon occupancy and OFF upon vacancy. Prior to connection to sensor head, the Power Control Module will cycle through a manufacturing test.
- Upon initial connection to a room controller, fixtures will coordinate their operation together within their daylighting zones. See Room Controller Instruction Sheet for information as to how to initiate this configuration process.
- Custom Configuration & System Refinement:** System Configuration may be refined using the Leviton Intellect™ application, downloadable from Google Play or the Apple Store, using any Bluetooth enabled Android or iOS Device. Use the application to:
 - Manually add/remove fixtures from the room
 - Add additional keypads to the room
 - Change sensor parameters like Sensitivity, Timeout, Target Light Level
 - Create user defined groups of fixtures
 - Define scenes (Meeting, Presentation, Lunch, Dinner, Test, etc.)
 - Monitor Energy Usage and view Energy Usage Trend
- For additional Information about Leviton's Intellect™ including product information, installation, use case diagrams and solution sheets, please visit www.Leviton.com/intellect.

EMERGENCY

The Intellect™ Power Control Module can be used as a UL 924 emergency bypass device ensuring that the relay is closed during a power failure condition and the 0-10V lines go to high impedance ensuring the load is at maximum output. Availability of input power to energize the load must be provided by connection to emergency panel.

When used for emergency lighting, the provided "Emergency Circuits" label shall be applied to the Intellect Power Control Module to be seen after device is installed. Also, the "Emergency Circuit Breaker" label shall be placed next to circuit breaker that is feeding the Power Control Modules so user is aware this breaker is an emergency lighting circuit.

When used for emergency lighting, the ZL027-0ES Emergency Sense Module is required and shall be connected using the supplied cable. The control input wires for the load control module are connected to emergency power, and the Emergency Sense Module is connected to normal power. Upon loss of normal power, the relay closes, and the 0-10V lines go to high impedance allowing the load to go to full output powered from the EM Source. Upon restoration of normal power, Power Control Module will automatically resume normal operation.

EMERGENCY WIRING

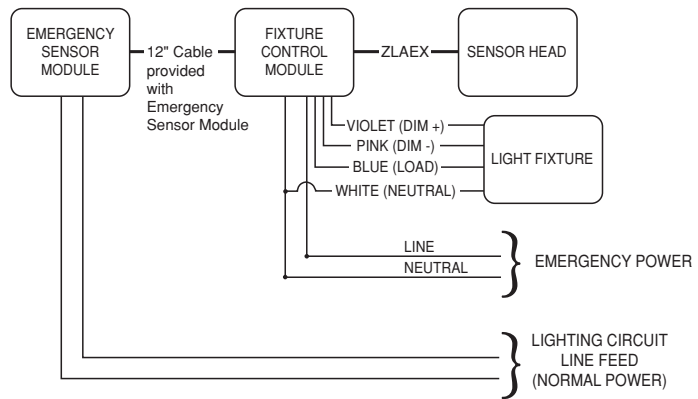

NOTE: Depending on date of manufacture, the pink 0-10V connector may be gray

FCC COMPLIANCE STATEMENT

This equipment has been tested and found to comply with the limits for a Class A digital device, pursuant to part 15 of the FCC Rules. These limits are designed to provide reasonable protection against harmful interference when the equipment is operated in a commercial environment. This equipment generates, uses and can radiate radio frequency energy and, if not installed and used in accordance with the instruction manual, may cause harmful interference to radio communications. Operation of this equipment in a residential area is likely to cause harmful interference in which case the user will be required to correct the interference at his own expense.

Any changes or modifications not expressly approved by Leviton could void the user's authority to operate this equipment.

FCC Suppliers Declaration of Conformity (sDoC): Model ZL027 manufactured by Leviton Manufacturing, Inc., 201 N Service Road, Melville, NY, <http://www.Leviton.com>. This device complies with part 15 of the FCC Rules. Operation is subject to the following two conditions: (1) This device may not cause harmful interference, and (2) this device must accept any interference received, including interference that may cause undesired operation.

INDUSTRY CANADA COMPLIANCE STATEMENT

This device complies with Industry Canada license-exempt RSS standard(s). Operation is subject to the following two conditions: (1) this device may not cause interference, and (2) this device must accept any interference, including interference that may cause undesired operation of the device.

IMPORTANT! Any changes or modifications not expressly approved by the party responsible for compliance could void the user's authority to operate this equipment.

This Class A digital apparatus complies with Canadian ICES-003.

Use herein of third party trademarks, service marks, trade names, brand names and/or product names are for informational purposes only, are/may be the trademarks of their respective owners; such use is not meant to imply affiliation, sponsorship, or endorsement.

FOR CANADA ONLY

For warranty information and/or product returns, residents of Canada should contact Leviton in writing at **Leviton Manufacturing of Canada ULC to the attention of the Quality Assurance Department, 165 Hymus Blvd, Pointe-Claire (Quebec), Canada H9R 1E9** or by telephone at **1 800 405-5320**.

LIMITED 5 YEAR WARRANTY AND EXCLUSIONS

Leviton warrants to the original consumer purchaser and not for the benefit of anyone else that this product at the time of its sale by Leviton is free of defects in materials and workmanship under normal and proper use for five years from the purchase date. Leviton's only obligation is to correct such defects by repair or replacement, at its option. **For details visit www.leviton.com or call 1-800-824-3005.** This warranty excludes and there is disclaimed liability for labor for removal of this product or reinstallation. This warranty is void if this product is installed improperly or in an improper environment, overloaded, misused, opened, abused, or altered in any manner, or is not used under normal operating conditions or not in accordance with any labels or instructions. **There are no other or implied warranties of any kind, including merchantability and fitness for a particular purpose,** but if any implied warranty is required by the applicable jurisdiction, the duration of any such implied warranty, including merchantability and fitness for a particular purpose, is limited to five years. **Leviton is not liable for incidental, indirect, special, or consequential damages, including without limitation, damage to, or loss of use of, any equipment, lost sales or profits or delay or failure to perform this warranty obligation.** The remedies provided herein are the exclusive remedies under this warranty, whether based on contract, tort or otherwise.