

e2XHD UTP Mini Panel

APPLICATION

The e2XHD UTP Mini Panel provides e2XHD cassette compatibility, allowing for copper and fiber connectivity in a single unit. The e2XHD Mini Panel will accommodate two e2XHD cassettes for either copper or fiber connectors. Flexible mounting options allow the e2XHD Mini Panel to be installed in a variety of wall-mount, rack, or cabinet applications.



SPECIFICATION

Mini panels shall consume no horizontal rack space and offer both copper and fiber compatibility. Mini panels shall accept two e2XHD cassettes, providing up to 12 copper or 24 fiber connections. Mini panels shall offer data ports at each rack position, allowing the use of shorter patch cords. Mini panels shall support multiple mounting applications including wall, rack, or cabinet.

FEATURES

- Consumes no horizontal rack space
- Compatible with QuickPort[®] copper and fiber connectors for maximum versatility
- Can share mounting hardware with existing equipment such as servers if necessary
- Accepts e2XHD cassettes for a wide range of fiber and copper connectors within a single device
- Can mount on back rail of cabinet, on the wall, to a rack or under the floor for maximum versatility
- Accommodates UTP copper solutions

DESIGN CONSIDERATIONS

- Uses no horizontal rack space
- Mounts on back rail of cabinet on the right or left side, wall, or rack
- Supports both fiber and copper connectors
- Routes cables vertically

STANDARDS & REGULATIONS

- ANSI/TIA-568.0-E

MECHANICAL SPECIFICATIONS

Dimensions:	6.45" (164 mm) W x 2.21" (56 mm) H x 3.00" (76 mm) D
Materials:	16-gauge steel enclosure 16-gauge steel cover
Capacity:	12 copper ports, 24 fibers

COUNTRY OF ORIGIN

USA

WARRANTY INFORMATION

For Leviton product warranties, go to leviton.com/ns/warranty

PRODUCT SPECIFICATIONS
E2XMB-D12

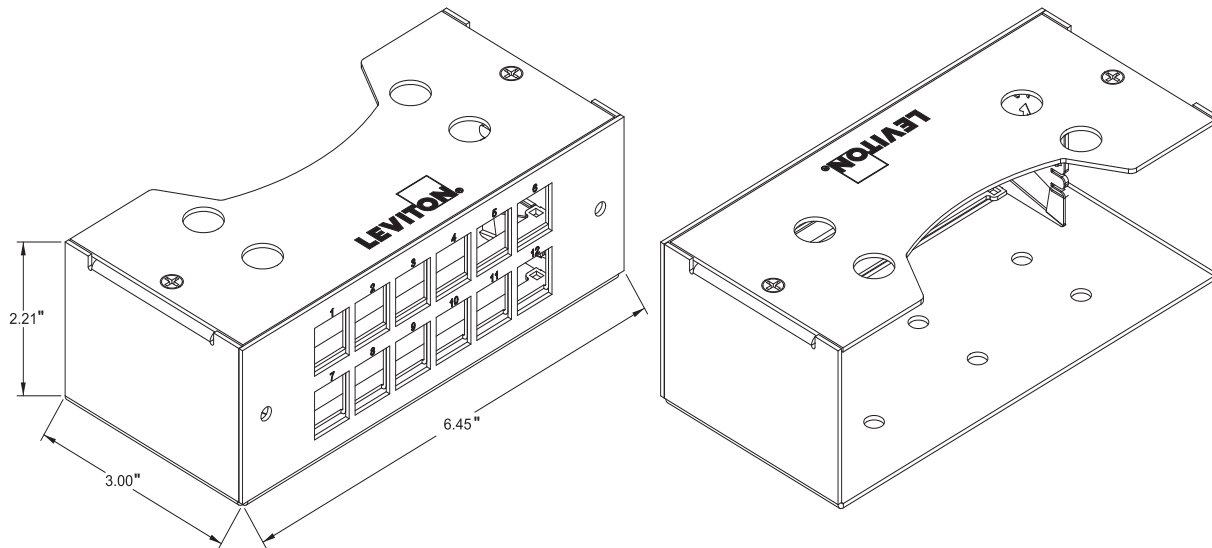

E2XMB-D12

E2XHD UTP MINI PANEL	
Description	Part No.
e2XHD UTP Mini Panel	E2XMB-D12

For further support information, visit leviton.com/ns/support

Page 2 of 2

USA
 Network Solutions Headquarters
 +1 (800) 722 2082
infoUSA@leviton.com
 Leviton Berk-Tek Cable: +1 (800) 237 5835
berktek.info@leviton.com

Asia Pacific
 +852 3620 2602
infoAPAC@leviton.com

Canada
 +1 (800) 461 2002
infoCanada@leviton.com

Europe
 +44 (0) 1592 772124
infoEurope@leviton.com

Latin America
 MX: +52 (55) 2128 6286
 LATAM: +52 (55) 2333 5963
infoLATAM@leviton.com

Middle East & Africa
 +971 (4) 247 9800
infoMEA@leviton.com

NETWORK SOLUTIONS PRODUCTS ARE AVAILABLE WORLDWIDE IN OVER 100 COUNTRIES. VISIT US ONLINE AT LEVITON.COM/NS TO LEARN MORE.