

SPECIFICATIONS

AEH50 Complete Five-Piece Surround-Sound Home Cinema Speaker System with 100 Watt Powered Subwoofer

JBL is a registered trademark of JBL, Incorporated.

Speaker complement

- Five 2-way magnetically-shielded satellite speakers with high-output 2.5 in (63.5 mm) woofer and precision .5 in (12.7 mm) tweeter
- One 8 in (200 mm) 100 Watt powered subwoofer with LFE input, adjustable level control, and built-in crossover network for use with speaker-level outputs.

Features

- Five-channel system is expandable to 6.1 and 7.1 surround-sound operation with optional additional AESS5 satellite speaker(s)
- Includes architectural-grade adjustable mounting brackets
- Includes subwoofer input RCA cable

Specifications

Satellites

| | |
|------------------------------------|--------------------------------------------|
| Frequency Response (+/- 3dB): | 150 Hz- 20 kHz |
| Recommended Amplifier Power Range: | 10- 100 Watts |
| Impedance: | Nominal 8 Ohms |
| Speaker Sensitivity (2.83V/1m): | 86 dB |
| Crossover Frequency (+/- 3dB): | 5000Hz, 6dB/octave |
| Midrange Driver(s): | 2-1/2" magnetically shielded |
| High-Frequency Transducer: | 1/2" magnetically shielded |
| Dimension (H x W x D): | 5" x 3-1/2" x 3-1/2" (127mm x 88mm x 88mm) |
| Weight per Speaker: | 1.25 lbs. (|

Subwoofer

| | |
|----------------------------------------|-------------------------------------------------|
| Amplifier | 100 Watts RMS |
| Frequency Response (+/- 3dB): | 35 Hz-150 Hz |
| Woofer: | 8" (200) |
| Enclosure type: | Bass-reflex |
| Dimension (H x W x D, including feet): | 16-1/4" x 11" x 13-3/4" (413mm x 279mm x 349mm) |
| Weight: | 28 lbs (12.7kg) |

LIMITED 5 YEAR WARRANTY AND EXCLUSIONS

Leviton warrants to the original consumer purchaser and not for the benefit of anyone else that this product at the time of its sale by Leviton is free of defects in materials and workmanship under normal and proper use for five years from the purchase date. Leviton's only obligation is to correct such defects by repair or replacement, at its option, if within such five year period the product is returned prepaid, with proof of purchase date, and a description of the problem to Leviton Manufacturing Co., Inc., Attn: Quality Assurance Department, 59-25 Little Neck Parkway, Little Neck, New York 11362-2591. This warranty excludes and there is disclaimed liability for labor for removal of this product or reinstallation. This warranty is void if this product is installed improperly or in an improper environment, overloaded, misused, opened, abused, or altered in any manner, or is not used under normal operating conditions or not in accordance with any labels or instructions. **There are no other or implied warranties of any kind, including merchantability and fitness for a particular purpose**, but if any implied warranty is required by the applicable jurisdiction, the duration of any such implied warranty, including merchantability and fitness for a particular purpose, is limited to five years. **Leviton is not liable for incidental, indirect, special, or consequential damages, including without limitation, damage to, or loss of use of, any equipment, lost sales or profits or delay or failure to perform this warranty obligation.** The remedies provided herein are the exclusive remedies under this warranty, whether based on contract, tort or otherwise.

000-AEH50-BL – Leviton IS Part number: DI-000-AEH50-02A
003-AEH50-WH- Leviton IS Part number: DI-000-AEH50-02A
000-AESS5-BL Leviton IS Part number: DI-000-AESS5-02A
003-AESS5-WH Leviton IS Part number: DI-000-AESS5-02A

Vendor part number: 406-000-05421-E
Vendor part number: 406-000-05421-E
Vendor part number: 406-000-05430-E
Vendor part number: 406-000-05430-E

All features and specifications are subject to change without notice.

*Trademarks of Dolby Laboratories.

DTS is a registered trademark of Digital Theater Systems, Inc.

Leviton Tech Support #2 1-800-824-3005
www.leviton.com



OWNER'S GUIDE

AEH50-BL
AEH50-WH

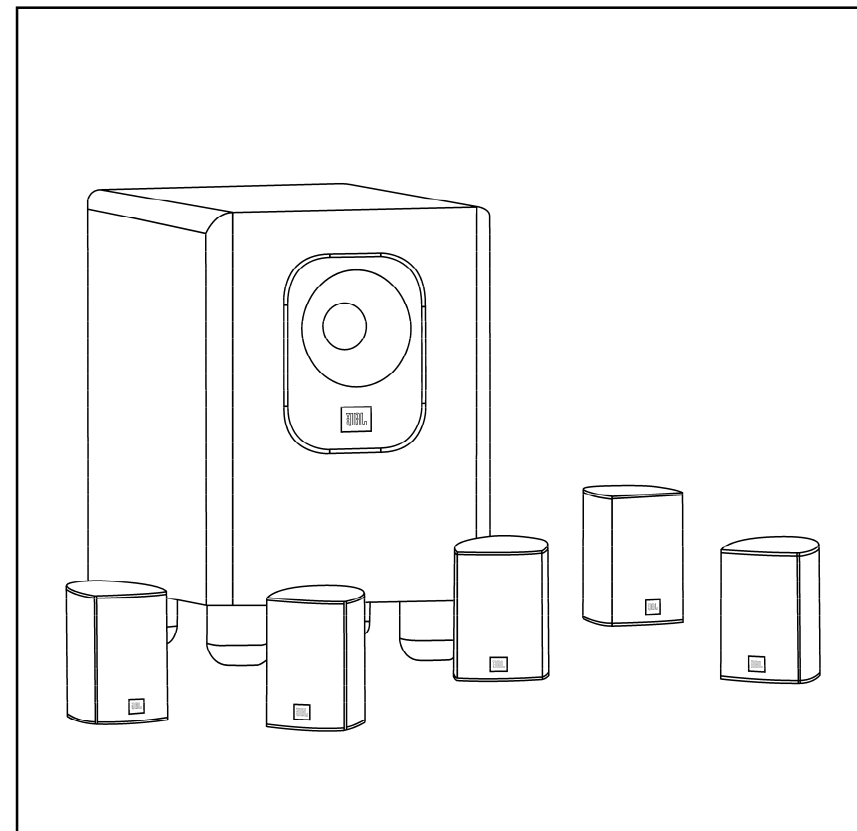

PN OWNER'S GUIDE

TABLE OF CONTENTS

- 3 Important Safety Precautions
- 4 Introduction
- 4 Unpacking the System
- 4 Planning Your System
- 5 Home Theater
- 6 Placement
- 7 Wall-Mounting the Satellites
- 7 Satellite Speaker Connections
- 8 Dolby* Digital or DTS®
- 8 Dolby Pro Logic* (Non-Digital) Line Level
- 9 Dolby Pro Logic (Non-Digital) Speaker Level
- 10 Operation
- 11 Troubleshooting
- 12 Specifications

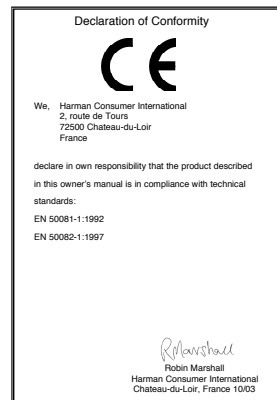

READ FIRST! Important Safety Precautions!

| |
|-------------------------------------------------------------------------------------------------------------------------------------------------------------------------------------------------------------------------------------------------------------------------------------------|
| <p>CAUTION RISK OF ELECTRIC SHOCK DO NOT OPEN</p> |
| <p>CAUTION: To reduce the risk of electric shock, do not remove cover (or back). No user-serviceable parts inside. Refer servicing to qualified service personnel.</p> |
| <p>CAUTION: To prevent electric shock, do not use this (polarized) plug with an extension cord, receptacle or other outlet unless the blades can be fully inserted to prevent blade exposure.</p> |
| <p> The lightning flash with arrowhead symbol, within an equilateral triangle, is intended to alert the user to the presence of uninsulated "dangerous voltage" within the product's enclosure that may be of sufficient magnitude to constitute a risk of electric shock to persons.</p> |
| <p> The exclamation point within an equilateral triangle is intended to alert the user to the presence of important operating and maintenance (servicing) instructions in the literature accompanying the appliance.</p> |

1. Read these instructions.
2. Keep these instructions.
3. Heed all warnings.
4. Follow all instructions.
5. Do not use this apparatus near water.
6. Clean only with a dry cloth.
7. Do not block any ventilation openings. Install in accordance with the manufacturer's instructions.
8. Do not install near any heat sources such as radiators, heat registers, stoves or other apparatus (including amplifiers) that produce heat.
9. Do not defeat the safety purpose of the polarized or grounding-type plug. A polarized plug has two blades with one wider than the other. A grounding-type plug has two blades and a third grounding prong. The wide blade or the third prong are provided for your safety. If the provided plug does not fit into your outlet, consult an electrician for replacement of the obsolete outlet.
10. Protect the power cord from being walked on or pinched, particularly at plugs, convenience receptacles and the point where they exit from the apparatus.
11. Only use attachments/accessories specified by the manufacturer.
12. Use only with the cart, stand, tripod, bracket or table specified by the manufacturer or sold with the apparatus. When a cart is used, use caution when moving the cart/apparatus combination to avoid injury from tip-over.

13. Unplug this apparatus during lightning storms or when unused for long periods of time.
14. Refer all servicing to qualified service personnel. Servicing is required when the apparatus has been damaged in any way, such as power-supply cord or plug is damaged, liquid has been spilled or objects have fallen into the apparatus, the apparatus has been exposed to rain or moisture, does not operate normally, or has been dropped.
15. Do not use attachments not recommended by the product manufacturer, as they may cause hazards.
16. This product should be operated only from the type of power source indicated on the marking label. If you are not sure of the type of power supply to your home, consult your product dealer or local power company. For products intended to operate from battery power, or other sources, refer to the operating instructions.
17. If an outside antenna or cable system is connected to the product, be sure the antenna or cable system is grounded so as to provide some protection against voltage surges and built-up static charges. Article 810 of the National Electrical Code, ANSI/NFPA 70, provides information with regard to proper grounding of the mast and supporting structure, grounding of the lead-in wire to an antenna discharge unit, size of grounding conductors, location of antenna-discharge unit, connection to grounding electrodes, and requirements for the grounding electrode. See Figure A.

18. An outside antenna system should not be located in the vicinity of overhead power lines or other electric light or power circuits, or where it can fall into such power lines or circuits. When installing an outside antenna system, extreme care should be taken to keep from touching such power lines or circuits, as contact with them might be fatal.
19. Do not overload wall outlets, extension cords, or integral convenience receptacles, as this can result in a risk of fire or electric shock.
20. Never push objects of any kind into this product through openings, as they may touch dangerous voltage points or short-out parts that could result in a fire or electric shock. Never spill liquid of any kind on the product.
21. Do not attempt to service this product yourself, as opening or removing covers may expose you to dangerous voltage or other hazards. Refer all servicing to qualified service personnel.
22. When replacement parts are required, be sure the service technician has used replacement parts specified by the manufacturer or that have the same characteristics as the original part. Unauthorized substitutions may result in fire, electric shock or other hazards.
23. Upon completion of any service or repairs to this product, ask the service technician to perform safety checks to determine that the product is in proper operating condition.
24. The product should be mounted to a wall or ceiling only as recommended by the manufacturer.

Figure A.
Example of Antenna Grounding as per National Electrical Code ANSI/NFPA 70

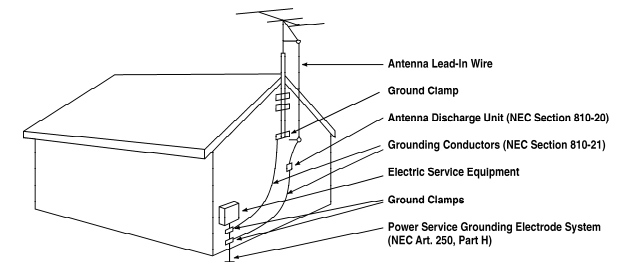

INTRODUCTION

UNPACKING THE SPEAKER

Carefully unpack the system. If you suspect damage from transit, report it immediately to your supplier and/or delivery service. Keep the shipping carton and packing materials for future use. Open the package and verify the following contents:

- Warranty Statement
- Powered subwoofer

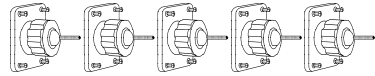
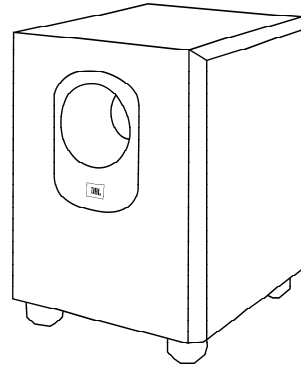

(5) Wall brackets for satellites

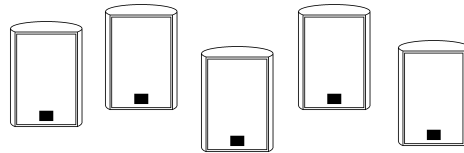

(5) Satellite speakers

- Wire Package
Contains:
2 x 40' Speaker wire
3 x 15' Speaker wire
1 x 15' Subwoofer cable

PLANNING YOUR SYSTEM

Before deciding where to best place your speakers, survey your room and study Figures 1 and 2.

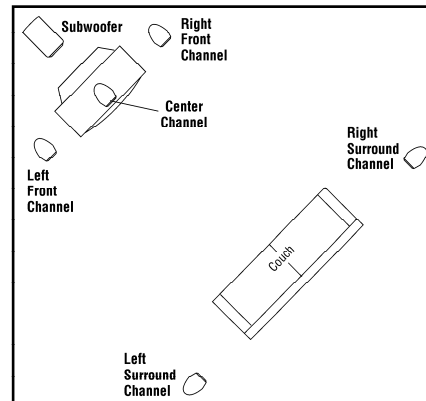
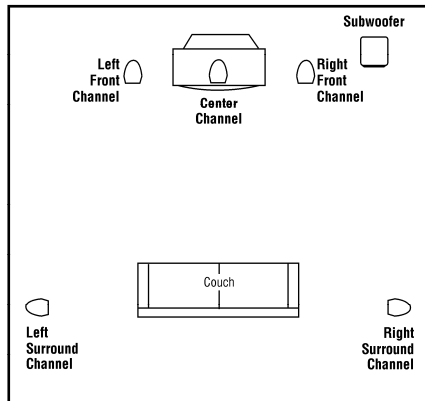

Figure 1. In this overhead view of a typical installation, satellite speakers are used to reproduce sound for the front and surround channels. The center channel reproduces sound and dialogue. The powered subwoofer provides bass for effects and music.

Figure 2. This figure shows an alternative layout, which may be more suitable for some rooms.

HOME THEATER

AEH50 BRACKET ASSEMBLY AND MOUNTING

IMPORTANT SAFETY NOTE:
Proper selection of mounting hardware not included herein and proper assembly and installation of brackets, including but not limited to selection of appropriate weight bearing support and bracket use with the specified speaker only is the exclusive responsibility of the customer. Manufacturer disclaims any liability for the selection of mounting hardware and or bracket installation.

- Loosen and remove the molded nut (2) by turning it counter clockwise. Use the supplied metal bar (5) if necessary by inserting it in one of the holes on the molded nut (2).
- Pull the ball/shaft (3) out of the wall bracket (4).
- Slide the molded nut (2) onto the ball/shaft (3) with threaded opening facing the ball, and thread on the metal nut (1) all the way onto the ball/shaft (3), with the nut (1)'s "knurled" surface facing away from the ball.
- Screw on the ball/shaft (3) into the threaded insert on the back of the speaker until it is fully seated against the bottom of the insert.
- Tighten the "knurled" nut (1) using a crescent wrench until it is firmly seated against the back of the speaker and has fully locked the ball/shaft (3) and the speaker cabinet together. Please note that once this nut is tightened, it may embed some marks on the back of the speaker where the attachment is made. However, these marks will be covered by the nut (1).
- Mount the wall bracket (4) onto a wood stud on the wall, using #10, minimum 1 inch long, wood screws. Make sure that all 4 screws are driven into the stud and not in drywall. If the bracket needs to be mounted on drywall, the use of properly selected and installed wall-anchors and screws is essential.
- Holding the speaker with both hands, reinsert the ball portion of the ball/shaft (3) into the wall bracket (4).
- Hand tighten the molded nut (2) while positioning the speaker for the intended orientation.
- Once the orientation of the speaker is finalized, use the metal bar (5) in one of the holes on the molded nut (2) and tighten securely.

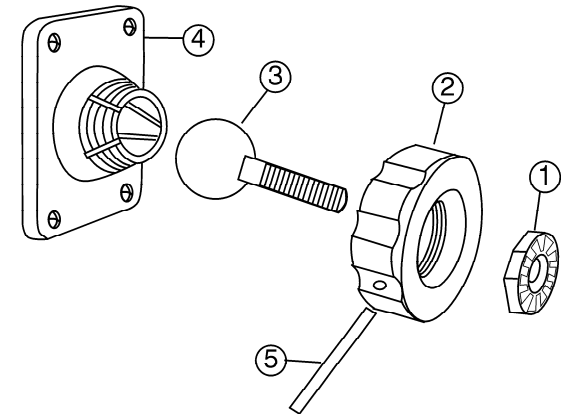

PLACEMENT

NOTE: The satellite speakers can be placed directly on a shelf, or mounted on a wall using the included wall brackets.

LEFT AND RIGHT FRONT CHANNELS

For left and right front channels, place one satellite to the left and another to the right of the television, as

shown in Figure 1. Since the speakers are magnetically shielded, you can place them very close to the TV

CENTER CHANNEL

For the center channel, place the speaker directly on top of, or below, your

television. Use included brackets for wall mounting.

SURROUND CHANNELS

For left and right surround channels, place one speaker on the left and another on

the right, to the side of or slightly behind the listening area. The surround speakers

SUBWOOFER

Since the installation of a subwoofer can be somewhat more complicated than installing full-range speakers, it is essential that you read this section very carefully prior to connecting the subwoofer to your system. Should you have questions relating to installation, it is advisable to call either your dealer or Leviton's Technical Support Department for advice.

The performance of the subwoofer is directly related to its placement in the listening room and how you align the subwoofer with the satellite speakers. Setting the volume of the subwoofer in relation to the left and right speakers is also of

critical importance because it is essential that the subwoofer integrate smoothly with the entire system. Setting the subwoofer's volume level too high will result in an overpowering, boomy bass. Setting the volume level too low will negate the benefits of the subwoofer.

Here are several additional facts on installation that may prove useful. It is generally believed that low frequencies (below 125Hz) are nondirectional and, therefore, placement of a subwoofer within any listening room is not critical. While in theory it is true that the larger wavelengths of extremely low frequencies are basically nondirectional,

without worrying about the magnetic field distorting the picture.

should be mounted at a height of between 4 feet and 7 feet.

the fact is that, when installing a subwoofer within the limited confines of a room, reflections, standing waves and absorptions generated within the room will strongly influence the performance of any subwoofer system. As a result, specific location of the subwoofer becomes important, and we strongly recommend that you experiment with placement before choosing a final location. Placement will depend upon your room (for example, whether or not your room permits placement of the subwoofer near either satellite) and the amount and quality of bass required.

WALL-MOUNTING THE SATELLITES

The satellites are designed to be mounted on the wall. There is a wall bracket for each satellite speaker. Each speaker bracket will require (4) 1-1/2" #10 wood screws; each screw should be fastened to a wall stud. If a wall stud is unavailable, install an anchor appropriate for a 1-1/2" #10 screw.

NOTE: The customer is responsible for the correct selection and use of mounting hardware (available through hardware stores)

that will ensure the proper and safe wall-mounting of the speakers.

Step 1.

Mark the positions on the wall where you would like to place the mounting screws.

Step 2.

Place bracket against wall and fasten four 1-1/2" #10 wood screws through the bracket's screw holes into the wall. If a wall stud is not available, use an appropriate anchor.

Step 3.

Screw the post of the bracket into the 1/4"-20 threaded insert on the back of the satellite. Adjust the satellite to the desired angle and tighten the knob.

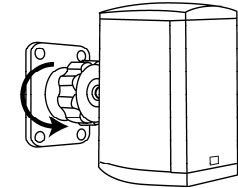

Figure 3. Bracket on wall.

SATELLITE SPEAKER CONNECTIONS

Turn Off All Power

After placing the speakers, you are ready to connect your system. First, turn off all audio-system power. Use high-quality CL2/3 rated speaker wire for in wall wire runs. #18-Gauge speaker wire with polarity coding is included for outside the wall use only. For longer distances, #16-gauge or heavier wire is recommended. The side of the wire with a ridge or other coding is usually considered positive polarity (i.e., +). Also, consult the owner's manuals that were included with your amplifier or receiver to confirm connection procedures.

Satellites

Observe polarities when making speaker connections, as shown in Figure 4. Connect each + terminal on the back of the amplifier or receiver to the respective + (red) terminal on each speaker. Connect the - (black) terminals in the same way.

Important!

Do not reverse polarities (i.e., + to - or - to +) when making connections. Doing so will cause poor imaging and diminished bass response. Be certain that positive and negative wire strands are completely isolated to avoid short circuits that may damage your equipment.

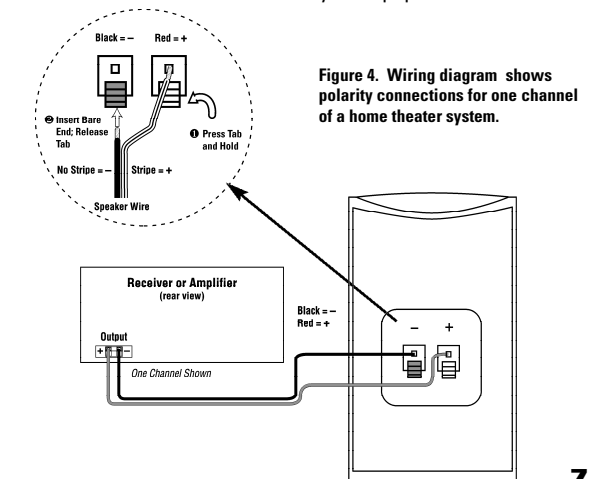
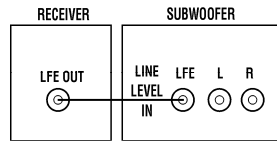

Figure 4. Wiring diagram shows polarity connections for one channel of a home theater system.

DOLBY® DIGITAL OR DTS® (OR OTHER DIGITAL SURROUND MODE) CONNECTION



Use this installation method for Dolby Digital, DTS or other digital surround processors:

Use the line-level input jack marked "LFE" for the Low-Frequency Effects channel.

Connect this jack to the LFE output or subwoofer output on your receiver or amplifier. Connect each speaker to the corresponding speaker terminals on your receiver or amplifier.

Make sure that you have configured your surround sound processor for "Subwoofer On." Also configure your receiver for 5.1-, 6.1- or

7.1-channel operation as appropriate. (Satellite speakers available separately) The front left, front right, center and rear speakers should all be set to "Small." If your receiver allows you to set the cross-over frequency between the subwoofer and the main speakers, select 120Hz or the setting that is the closest frequency below it.

DOLBY PRO LOGIC® (NON-DIGITAL) – LINE LEVEL

Use this installation method for Dolby Pro Logic applications (not Dolby Digital, DTS or other digital processing), where the receiver/processor is equipped with a subwoofer output, or a volume-

controlled preamp (line-) level output:

Use RCA-type interconnects to connect the line-level subwoofer outputs on your receiver or amplifier to the line-level inputs on the subwoofer.

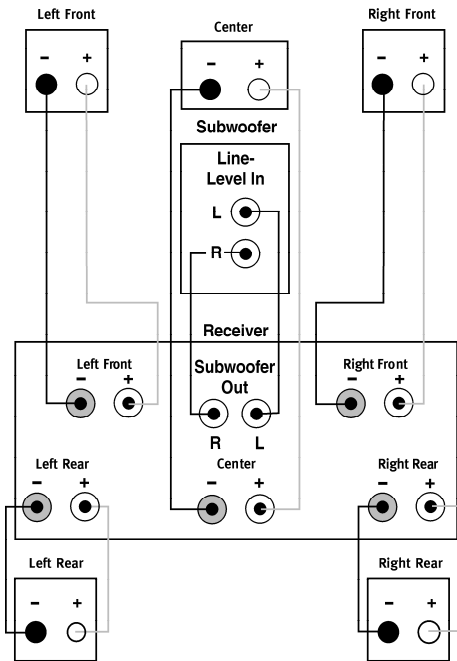

IMPORTANT: Do not use the LFE input on the subwoofer with Dolby Pro Logic processors.

NOTE: If your receiver or amplifier only has one subwoofer output jack, then you will need to use a Y-connector (not included). Plug the male end of the Y-connector into your receiver or amplifier's subwoofer output jack, and connect each of the two female ends to separate RCA-type interconnects. Finally, plug the RCA-type interconnects into the line-level inputs on the subwoofer.

Connect each speaker to the corresponding speaker terminals on your receiver or amplifier.

Make sure your receiver or processor is correctly configured to indicate that the subwoofer is "On."

Note for advanced users: If your receiver/processor has a built-in low-pass crossover filter for the subwoofer output, you may use the LFE input to bypass the subwoofer's internal crossover.

DOLBY PRO LOGIC (NON-DIGITAL) – SPEAKER LEVEL

Use this installation method for Dolby Pro Logic applications (not Dolby Digital, DTS or other digital processing), where the receiver/processor does not have a subwoofer output, or a volume-controlled preamp (line-) level output:

Connect your receiver or amplifier's front left and right speaker terminals to the left and right terminals on the subwoofer that are marked "Speaker Level In." Connect the left and right terminals on the subwoofer that are marked "Speaker Level Out" to the corresponding terminals on the back of your front left and right speakers.

Connect your receiver or amplifier's center, surround and surround back speaker terminals to the corresponding terminals on the back of your center and surround speakers.

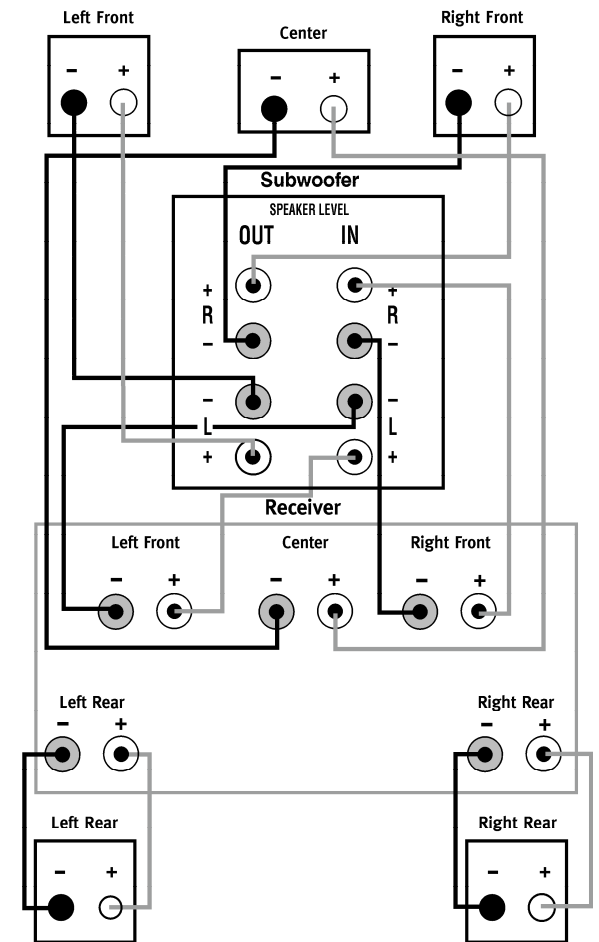

OPERATION

Move the Master Power switch (marked "Power" **A**) to the "•" (On) position to use the subwoofer.

If you will be away from home for an extended period of time, or if the subwoofer will not be used, switch the Master Power switch **A** to the Off position.

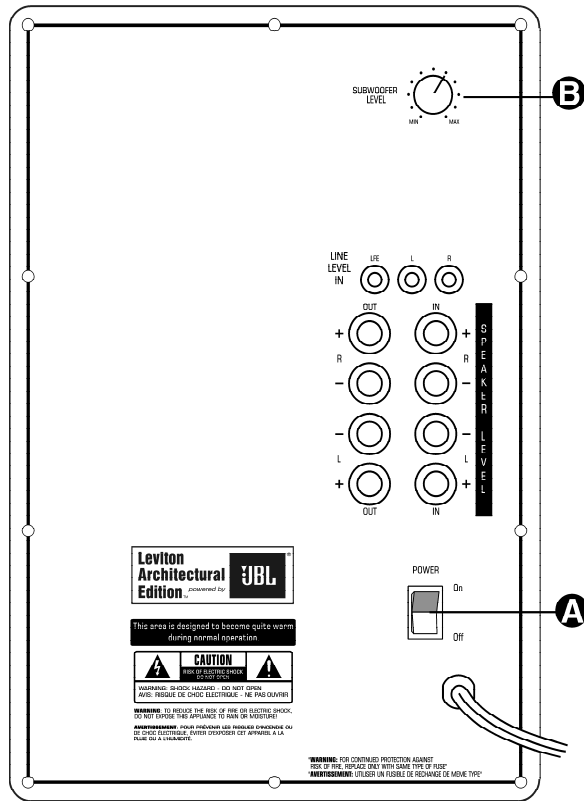

VOLUME

Volume may be adjusted using the Subwoofer Level control **B** as shown.

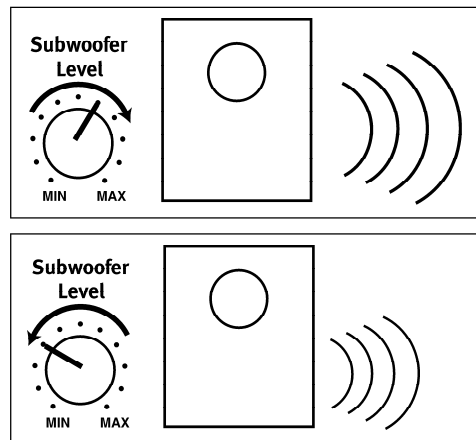

TROUBLESHOOTING

If there is no sound from any of the speakers:

- Check that receiver/amplifier is on and a source is playing.
- Check that the powered subwoofer is plugged in, and its Power switch **A** is switched on ("•" position).
- Check all wires and connections between receiver/amplifier and speakers. Make sure all wires are connected. Make sure none of the speaker wires are frayed, cut or punctured, or touching each other.
- Review proper operation of your receiver/amplifier.

If there is no sound coming from one speaker:

- Check the "Balance" control on your receiver/amplifier.
- Check all wires and connections between receiver/amplifier and speakers. Make sure all wires are connected. Make sure none of the speaker wires are frayed, cut or punctured, or touching each other.
- In Dolby Digital or DTS modes, make sure that the receiver/processor is configured so that the speaker in question is enabled.
- Turn off all electronics and switch the speaker in question with one of the other speakers that is working correctly. Turn everything back on, and determine whether the problem has followed the speaker, or has remained in the same channel. If the problem is in the same channel, the source of the problem is most likely with your receiver or amplifier, and you should consult the

owner's manual for that product for further information. If the problem has followed the speaker, consult your dealer for further assistance.

If there is no sound from the center speaker:

- Check all wires and connections between receiver/amplifier and speaker. Make sure all wires are connected. Make sure none of the speaker wires are frayed, cut or punctured, or touching each other.
- If your receiver/processor is set in Dolby Pro Logic mode, make sure the center speaker is not in phantom mode.
- If your receiver/processor is set in one of the Dolby Digital or DTS modes, make sure the receiver/processor is configured so that the center speaker is enabled.

If the system plays at low volumes but shuts off as volume is increased:

- Check all wires and connections between receiver/amplifier and speakers. Make sure all wires are connected. Make sure none of the speaker wires are frayed, cut or punctured, or touching each other.
- If more than one pair of main speakers is being used, check the minimum impedance requirements of your receiver/amplifier.

If there is low (or no) bass output:

- Make sure the connections to the left and right "Speaker Inputs" have the correct polarity (+ and -).
- Make sure the subwoofer is plugged into an active electrical outlet, and is

turned on (Power switch **A** in the "•" position).

- In Dolby Digital or DTS modes, make sure your receiver/processor is configured so that the subwoofer and LFE output are enabled.

If there is no sound from the rear speakers:

- Check all wires and connections between receiver/amplifier and speakers. Make sure all wires are connected. Make sure none of the speaker wires are frayed, cut or punctured, or touching each other.
- Review proper operation of your receiver/amplifier and its surround sound features.
- Make sure the movie or TV show you are watching is recorded in a surround sound mode. If it is not, check to see whether your receiver/amplifier has other surround modes you may use.
- In Dolby Digital or DTS modes, make sure your receiver/processor is configured so that the rear speakers are enabled. When six satellites are in use, remember to configure your receiver or processor for 6.1-channel operation, and when seven satellites are in use, configure your receiver or processor for 7.1 channels.

- Review the operation of your DVD player and the jacket of your DVD to make sure that the DVD features the desired Dolby Digital or DTS mode, and that you have properly selected that mode using both the DVD player's menu and the DVD disc's menu.